

Projekt domu Garaż G5

autor: Karolina Pawłowska
cena projektu: 990 zł



dobredomy
flak & abramowicz

Powierzchnia użytkowa	44,80 m²
Powierzchnia zabudowy	58,10 m ²
Kubatura netto	157,50 m ³
Powierzchnia dachu skośnego	102,00 m ²
Kąt nachylenia dachu	40°
Wysokość budynku	6,40 m
Min. wymiary działki dł.	13,52 m
Min. wymiary działki szer.	17,52 m
Liczba pokoi	0
Liczba łazienek	0
Garaż	2

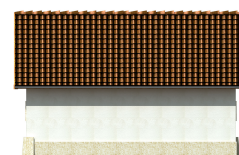
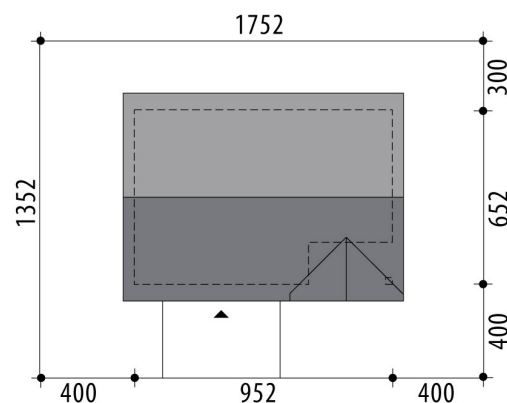

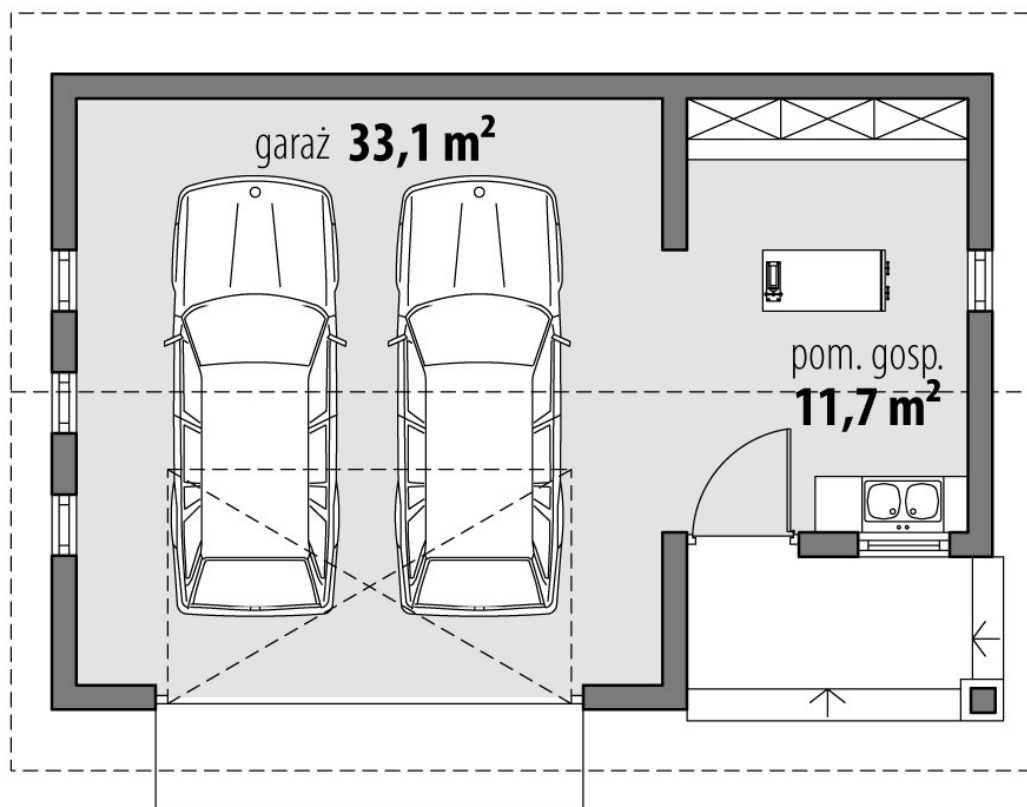

RZUT PARTER

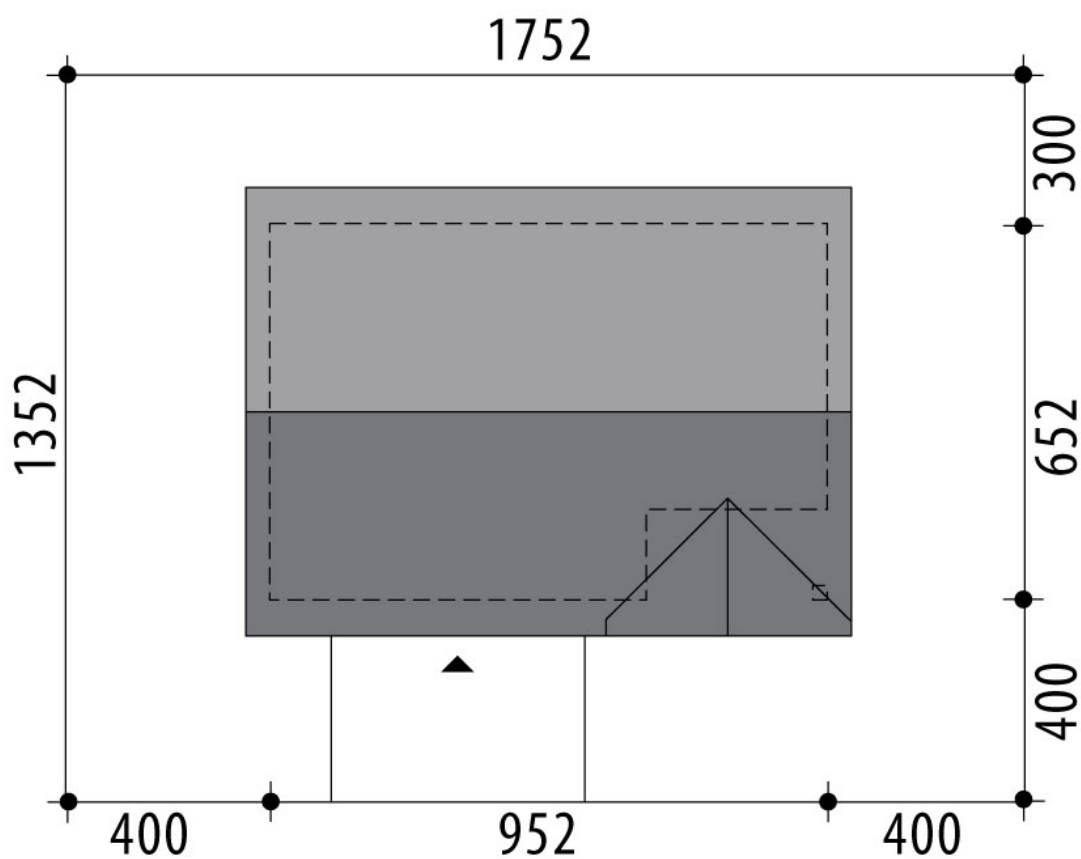

RZUT DZIAŁKI

