

# Projekt domu Amon II

autor: Tomasz Flak

cena projektu: 4 660 zł



<b>Powierzchnia użytkowa</b>	<b>115,40 m<sup>2</sup></b>
<b>+ powierzchnia garażu</b>	<b>17,40 m<sup>2</sup></b>
Powierzchnia zabudowy	118,00 m <sup>2</sup>
Kubatura netto	515,50 m <sup>3</sup>
Powierzchnia dachu skośnego	204,00 m <sup>2</sup>
Kąt nachylenia dachu	40°
Wysokość budynku	8,30 m
Min. wymiary działki dł.	22,62 m
Min. wymiary działki szer.	17,82 m
Liczba pokoi	4
Liczba łazienek	2
Garaż	1

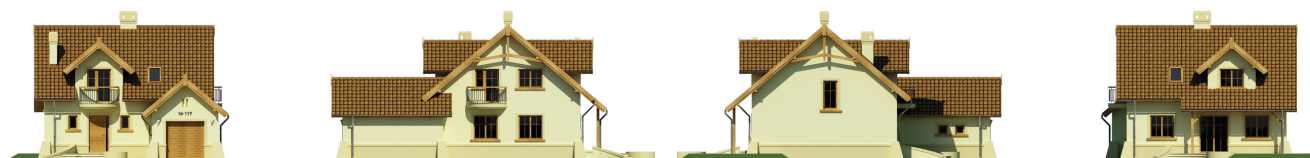
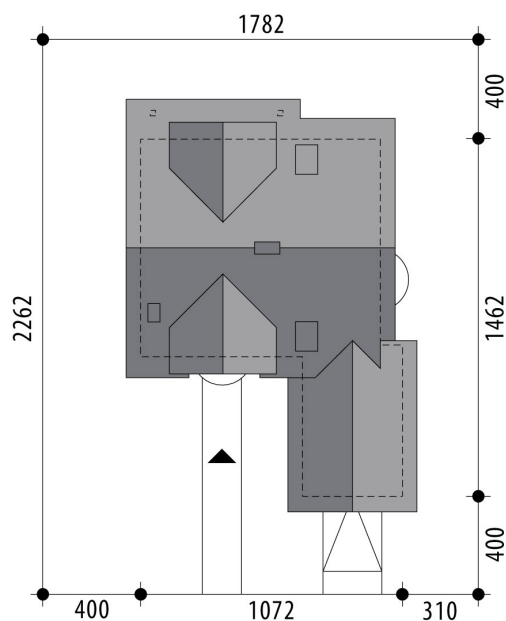

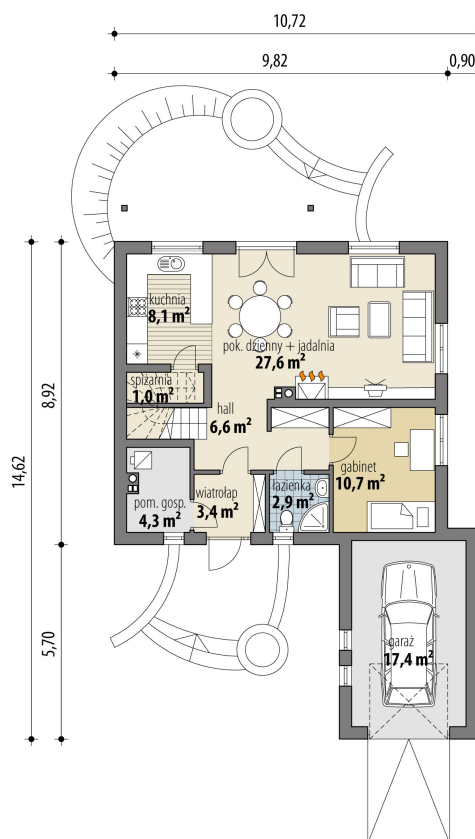

RZUT PARTER

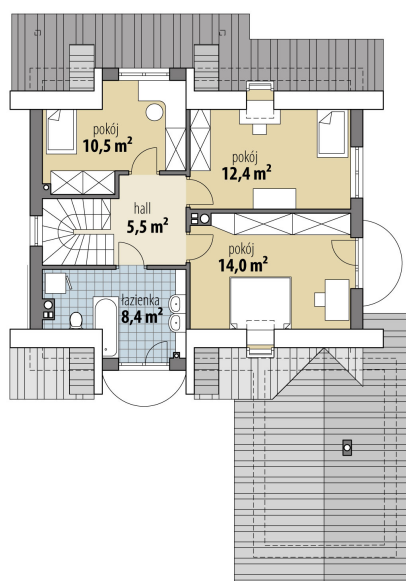

RZUT

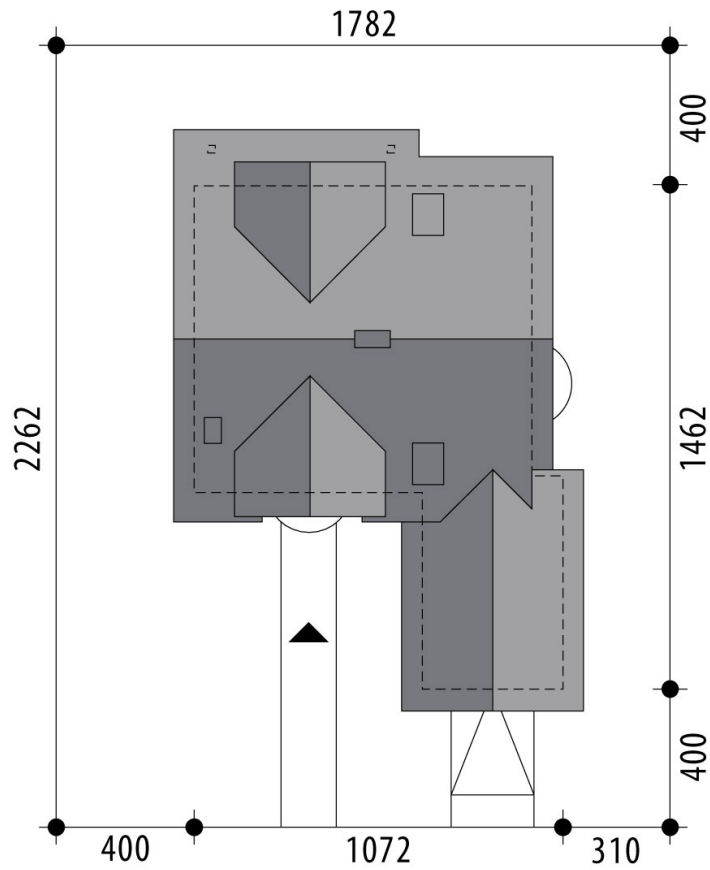

RZUT DZIAŁKI

