

Projekt domu Garaż G6

autor: Tomasz Flak
cena projektu: 990 zł

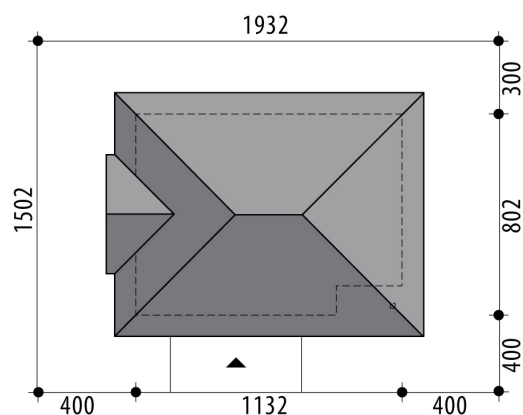

Powierzchnia użytkowa	66,60 m²
+ powierzchnia strychu	12,00 m²
Powierzchnia zabudowy	87,50 m ²
Kubatura netto	222,00 m ³
Powierzchnia dachu skośnego	157,00 m ²
Kąt nachylenia dachu	35°
Wysokość budynku	6,10 m
Min. wymiary działki dł.	15,02 m
Min. wymiary działki szer.	19,32 m
Liczba pokoi	0
Liczba łazienek	0
Garaż	2



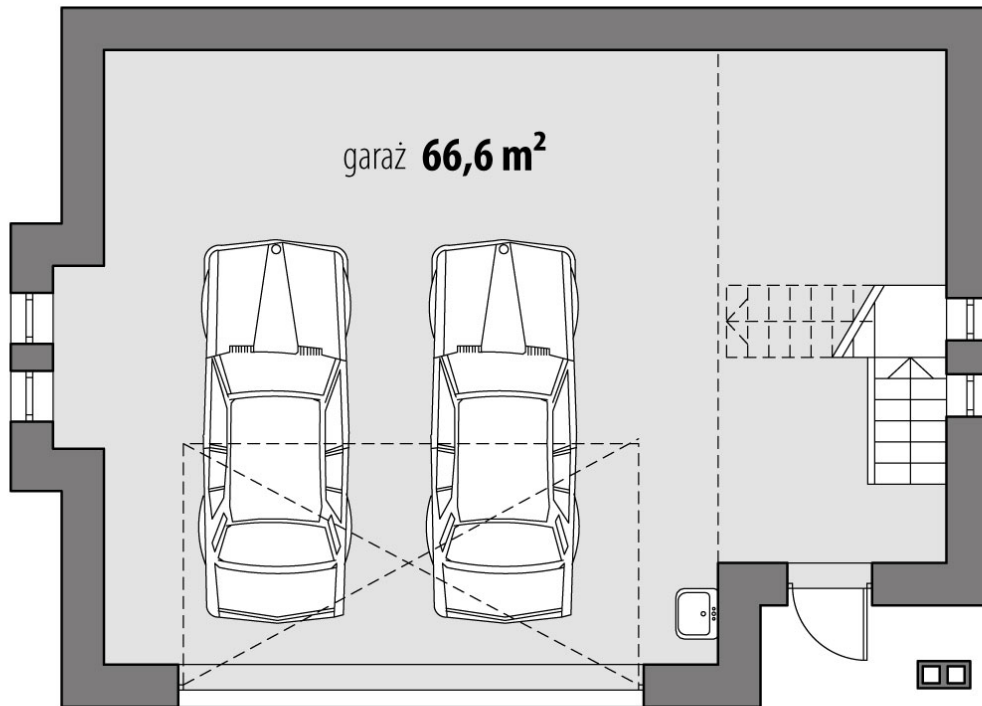

RZUT PARTER

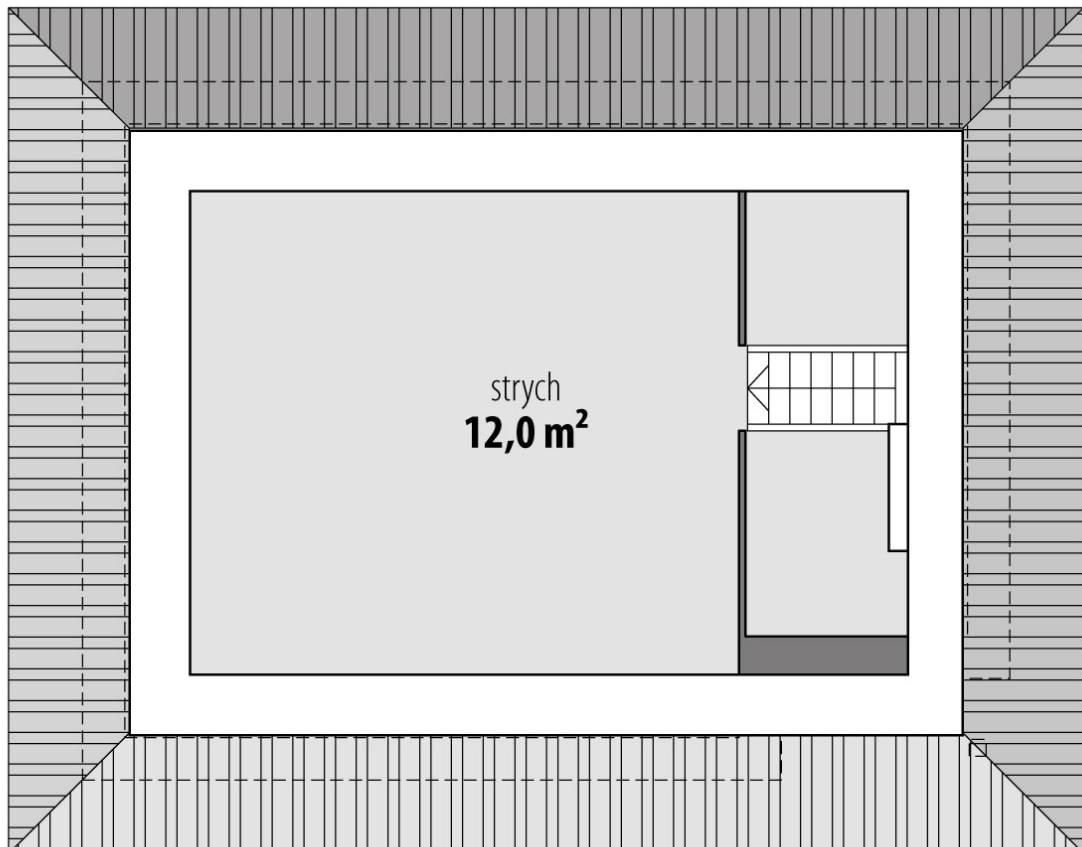

RZUT

