

Projekt domu Aniela

autor: Marcin Abramowicz Jagoda Gruca
cena projektu: 4 660 zł

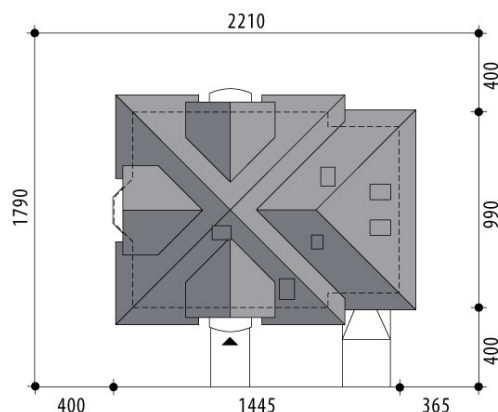

Powierzchnia użytkowa	126,50 m²
+ powierzchnia garażu	18,10 m²
+ powierzchnia pom. gosp.	5,80 m²
+ powierzchnia strychu	11,50 m²
Powierzchnia zabudowy	130,40 m ²
Kubatura netto	492,00 m ³
Powierzchnia dachu skośnego	232,40 m ²
Kąt nachylenia dachu	40°
Wysokość budynku	8,60 m
Min. wymiary działki dł.	17,90 m
Min. wymiary działki szer.	22,10 m
Liczba pokoi	4
Liczba łazienek	2
Garaż	1



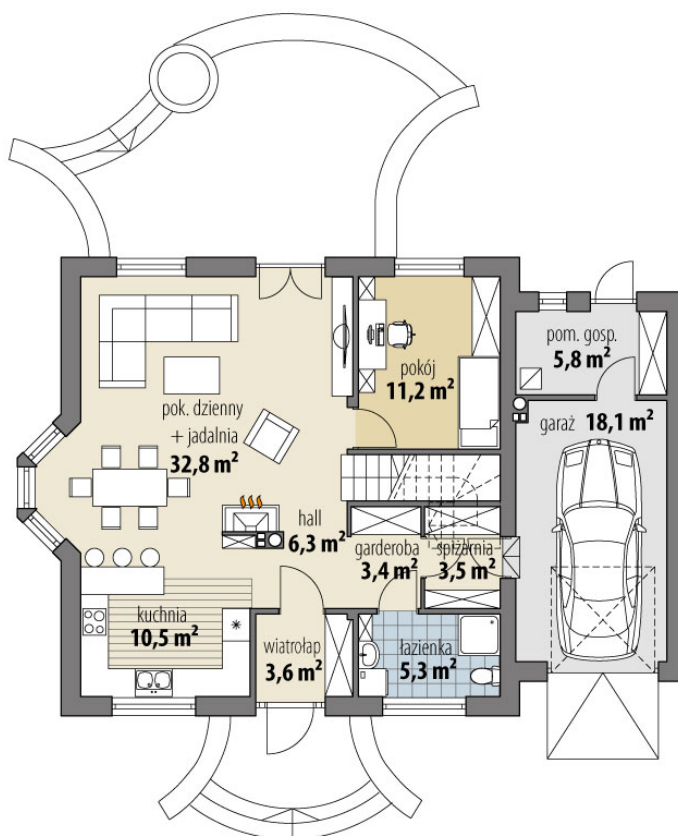

RZUT PARTER

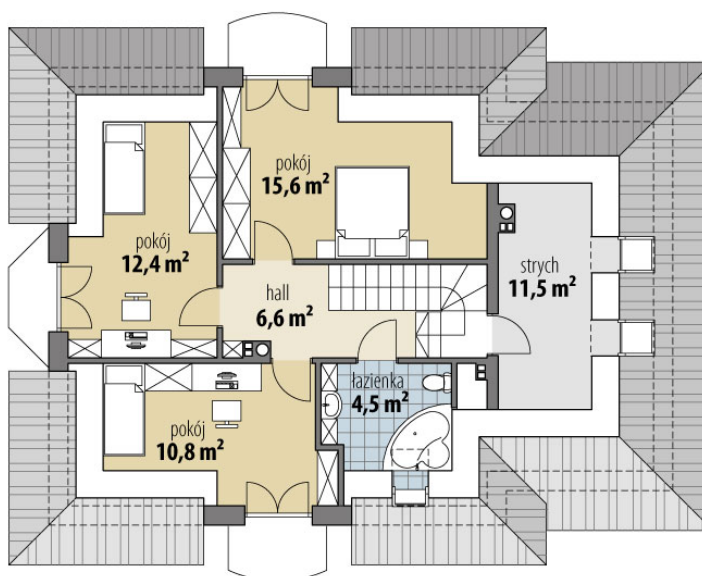

RZUT

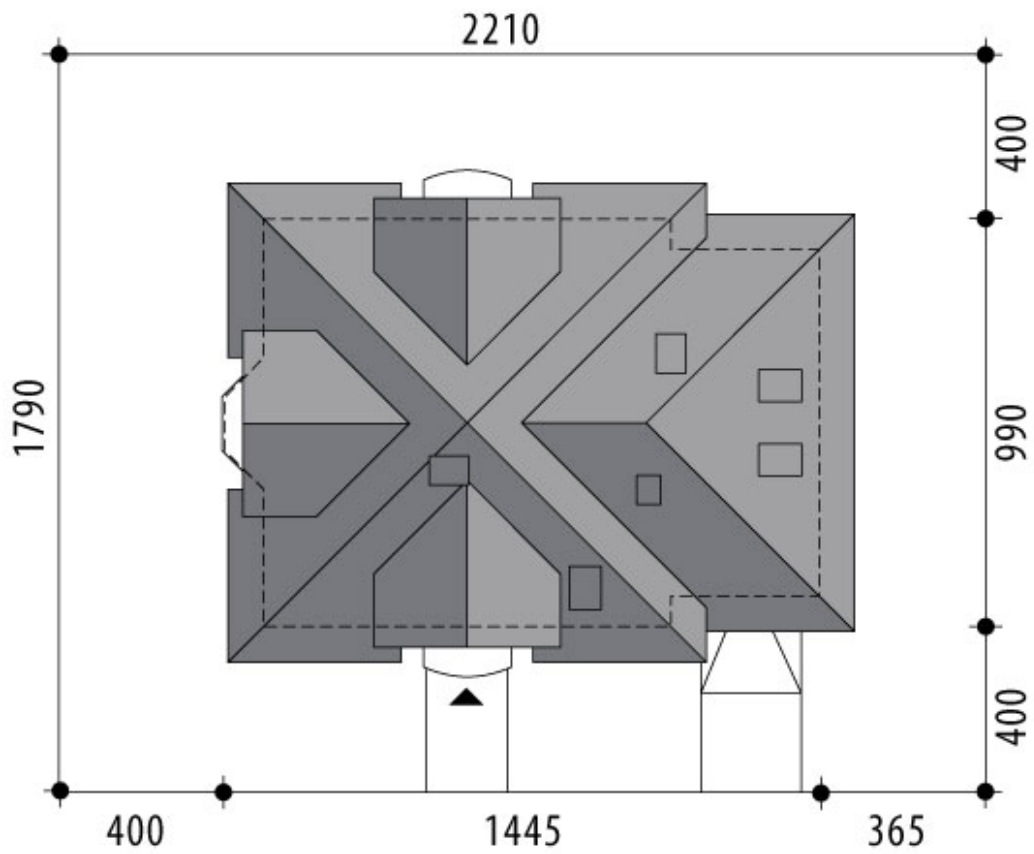

RZUT DZIAŁKI

