

# Projekt domu Benedykt II

autor: Marcin Abramowicz Marta Zaperty-Adamek  
cena projektu: 4 240 zł

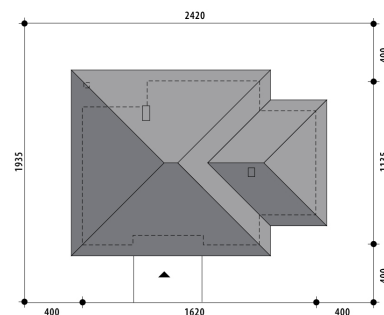

<b>Powierzchnia użytkowa</b>	<b>99,50 m<sup>2</sup></b>
<b>+ powierzchnia garażu</b>	<b>22,80 m<sup>2</sup></b>
Powierzchnia zabudowy	167,70 m <sup>2</sup>
Kubatura netto	356,90 m <sup>3</sup>
Powierzchnia dachu skośnego	243,90 m <sup>2</sup>
Kąt nachylenia dachu	30°
Wysokość budynku	6,90 m
Min. wymiary działki dł.	19,35 m
Min. wymiary działki szer.	24,20 m
Liczba pokoi	3
Liczba łazienek	2
Garaż	1



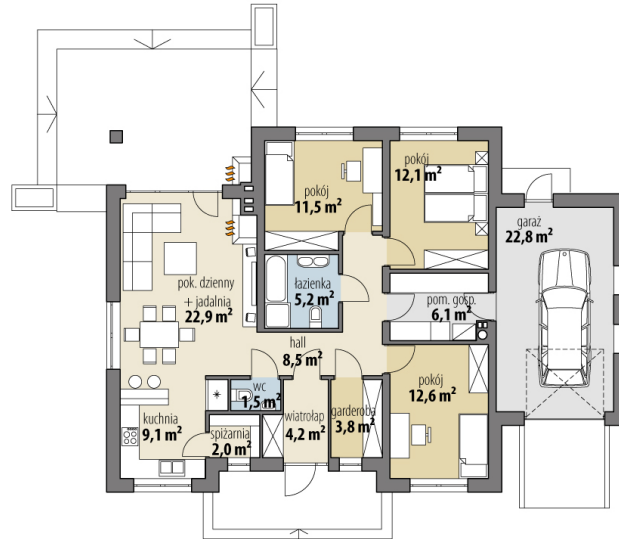

RZUT PARTER

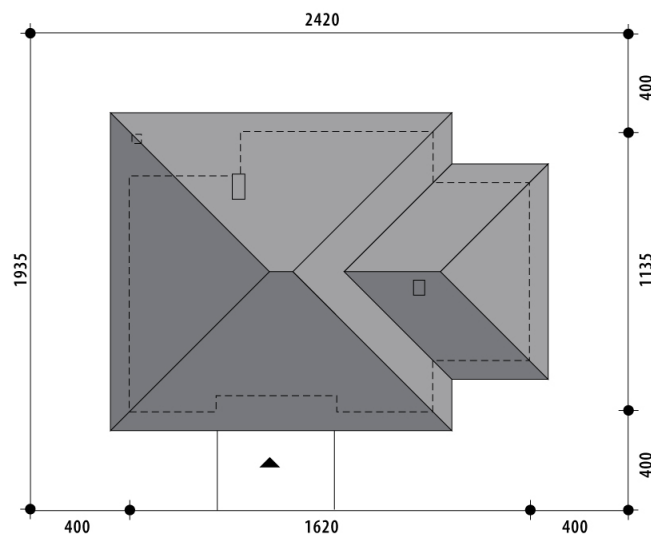

RZUT DZIAŁKI



